

Threaded stud with reduced shaft (type RD acc. to DIN EN ISO 13918)

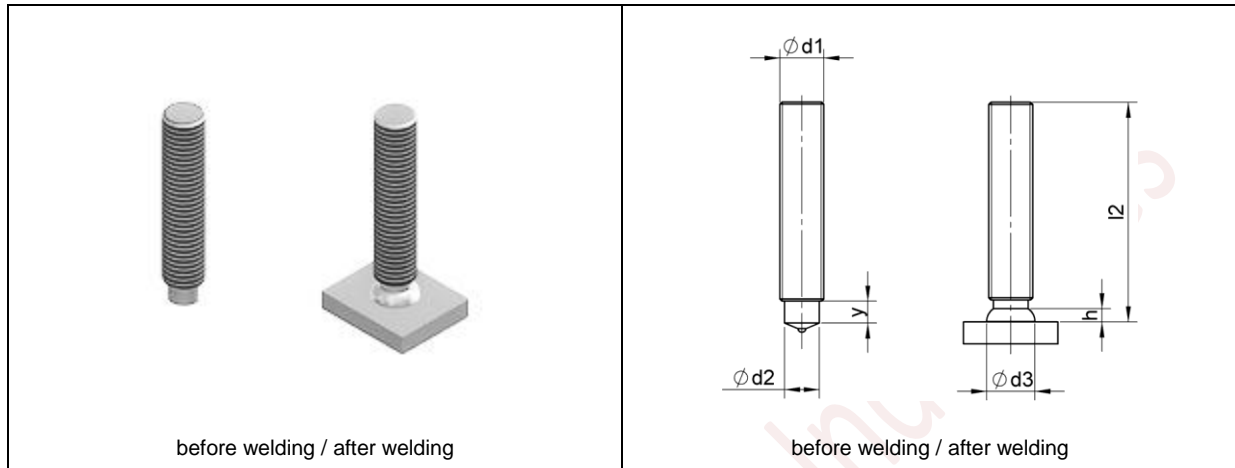

Dimensions					
d1	l2	y1 -0/2P ²	d2 -0.1/0.1	d3*	h*
M6	15-100	4	4.7	7	2.5
M8	15-100	4	6.2	9	2.5
M10	15-100	5	7.9	11.5	3
M12	20-100	6	9.5	13.5	4
M16	25-100	7.5	13.2	16.8	5
M16	25-100	11	13.2	16.1	5
M20	30-100	13	16.5	23	6
M24	50-100	15	20	28	7

1. Other y-dimensions available on request.
2. P = thread pitch acc. to DIN 13-1
3. for l2 < 20 mm

*d3 and h are approximate values.